

## SMT660/890

### High Performance Bi-Color TOP LED

SMT660/890 consists of an AlGaAs LEDs mounted on the lead frame as TOP LED package and is sealed with epoxy resin. It emits a spectral band of radiation at 650 and 890nm at anode common.

<Specifications>

1. Product Name: Bi-Color TOP LED
2. Type Number: SMT660/890
3. Chip:
  - Chip Material: AlGaAs
  - Peak Wavelength: 680,890nm
4. Package
  - Lead Frame Die: Silver Plated
  - Package Resin: PPA Resin
  - Lens: Epoxy or Silicone Resin

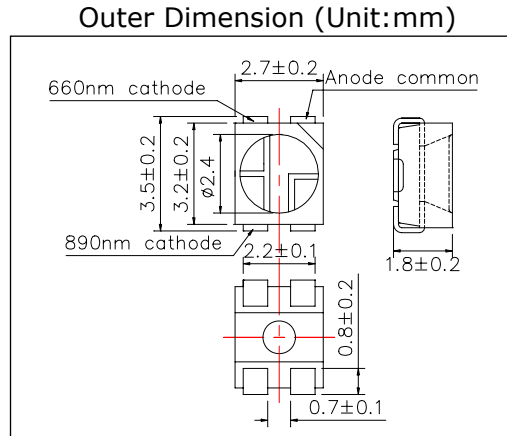

Absolute Maximum Ratings [Ta=25°C]				
Item	Symbol	Maximum Rated Value		Unit
		660nm	890nm	
Power Dissipation	PD	75	150	mW
Forward Current	IF	30	100	mA
Reverse Voltage	VR	5		V
Operating Temperature	TOPR	-20 ~ +80		°C
Storage Temperature	TSTG	-30 ~ +80		°C
Soldering Temperature*	TSOL	240		°C

\* Soldering condition must be completed within 3 second at 230 °C.

Electro-Optical Characteristics [Ta=25°C ]									
Item	Symbol	Condition	Minimum		Typical		Maximum		Unit
			660	890	660	890	660	890	
Forward Voltage	VF	IF=20mA			1.9	1.3	2.2	1.5	V
Reverse Current	IR	VR=5V					10		uA
Total Radiated Power*	PO	IF=20mA	1.5	2.0	2.5	3.5			mW
Radiant Intensity**	IE	IF=20mA			1.5	3.0			mcd
Peak wavelength	λP	IF=20mA	640	875	650	890	660	905	nm
Half Width	Δλ	IF=20mA			20	75			nm
Viewing Half Angle	θ1/2	IF=20mA			±55				deg

\* Measured by Photodyne #500

\*\* Measured by Tektronix J-6512

