

# MODEL DF8V series

## 280nm Naked Bare Die (Flip chip form)

**APPLICATIONS**

- Analytical instruments  
-Bio chemical, medical, and scientific analysis
- Photo Catalyst
- Medical Phototherapy
- UV Curing  
-Spot bonding, printing, film coating, and general purpose

**OPTION**

- On Low Profile Silicon Submount
- On Large Silicon Submount

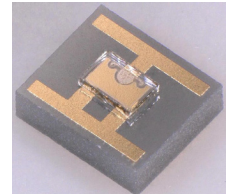

View of "Die on AlN Submount(Large)"

**Typical Optical-Electrical Characteristics ( $I_F=20\text{mA}$ ,  $T_a=25^\circ\text{C}$ )** Note 1

Item	Symbol	Unit	Min	Typ	Max
Peak Wavelength	$\lambda_p$	nm	270	(280)*	290
Radiant Flux	$P_o$	mW	1.0	2.2	-
Full Width at Half Maximum	$\Delta\lambda$	nm	-	12	-
Forward voltage	$V_F$	V		6.5	7.5
Reverse Current ( $V_R = 5\text{V}$ )	$I_R$	$\mu\text{A}$	-	-	1
Viewing Half Angle	$2\theta_{1/2}$	deg.	-	144	-

\*Nominal value

**Absolute Maximum Ratings ( $T_a=25^\circ\text{C}$ )** Note 2

Item	Symbol	Unit	
Forward Current	$I_{Fmax}$	mA	40
Reverse Voltage	$V_{Rmax}$	V	5
Operating Temperature	$T_{OPR}$	$^\circ\text{C}$	-30 ~ +80
Storage Temperature	$T_{STG}$	$^\circ\text{C}$	-40 ~ +100

**Note:**

1. Typical values given are within the range of average expected by the manufacturer in large quantities and are provided for information only. All measurements were made using a Au-plated TO5 header without an encapsulant. Optical characteristics measured in an integrating sphere using radiant flux  $P_o$ .
2. Maximum ratings are package-dependent. The above ratings were determined using a Au-plated TO5 header without an encapsulant for characterization. Ratings for other packages may differ. Assembly processing temperature must not exceed  $300^\circ\text{C}$  (< 5 seconds).
3. Specifications are subject to change without notice.

**Part Number and Chip Outlines (Unit:  $\mu\text{m}$ )**

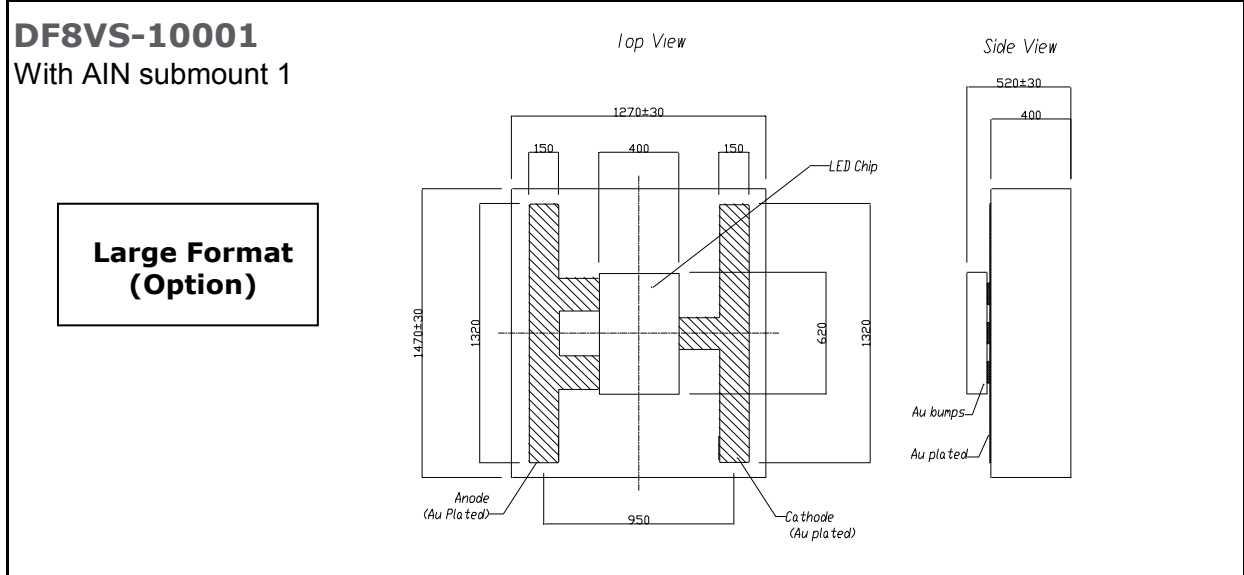
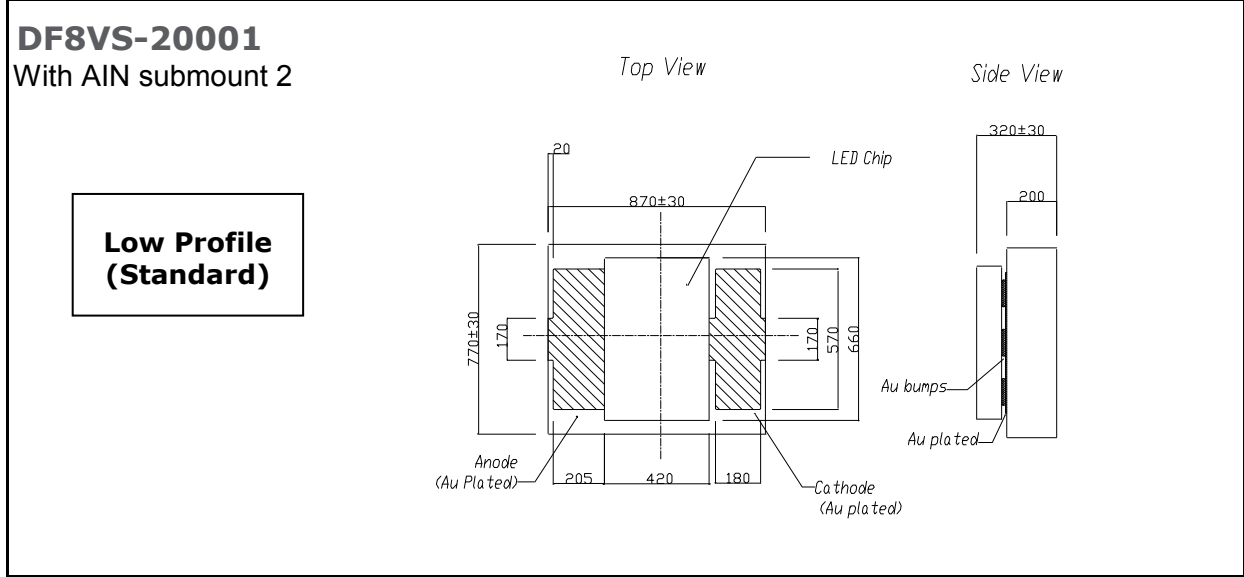
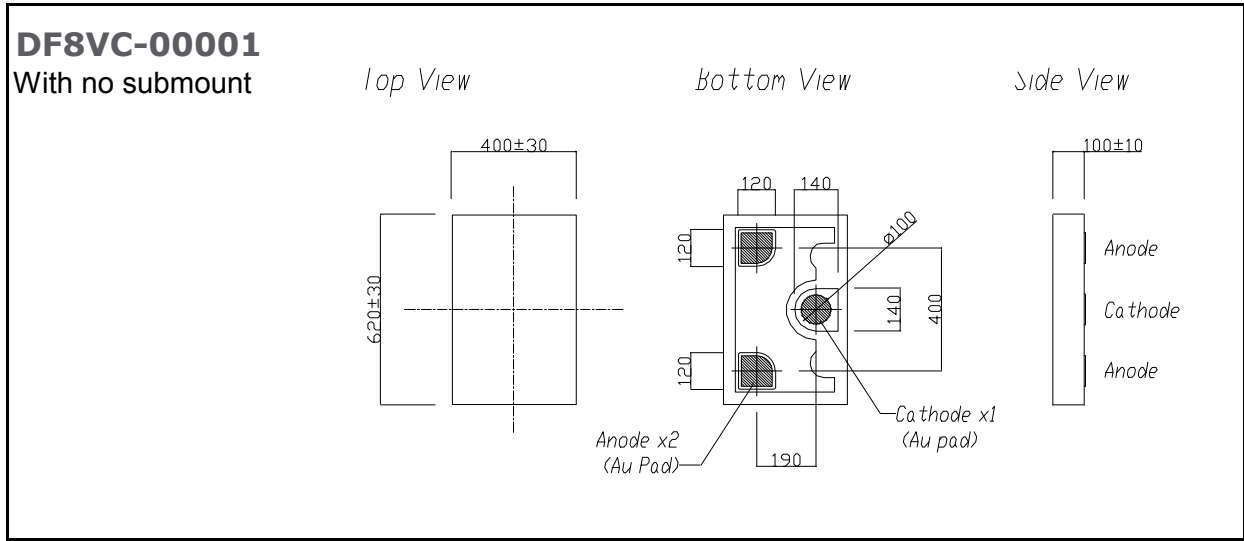

### Characteristic Curves

These are representative measurements for this LED product. Actual curves will vary slightly for the various radiant flux.

**Forward Current vs Forward Voltage**

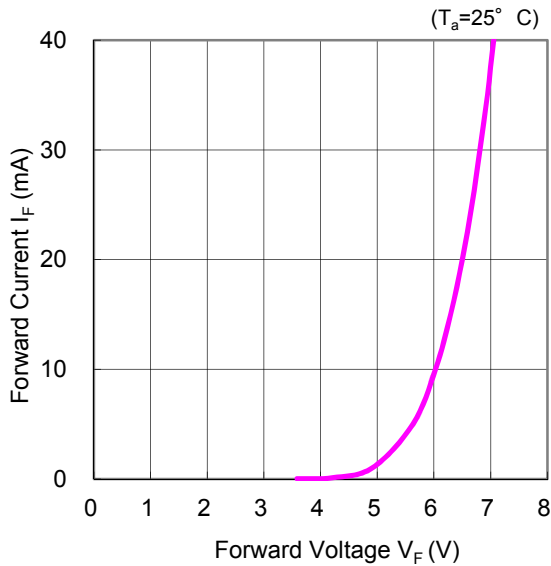

**Forward Current vs Radiant Flux**

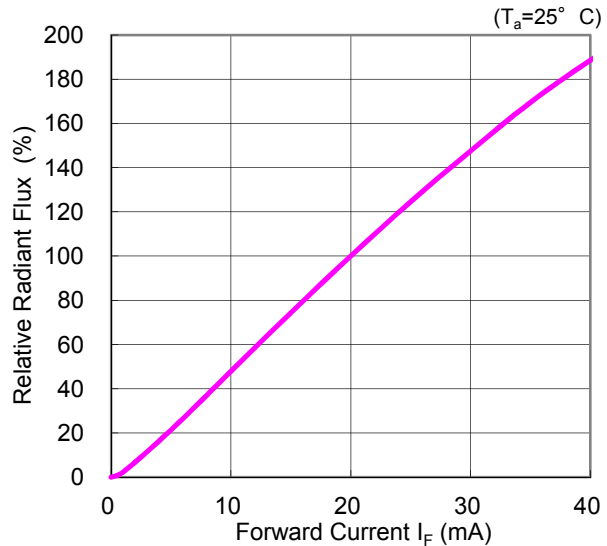

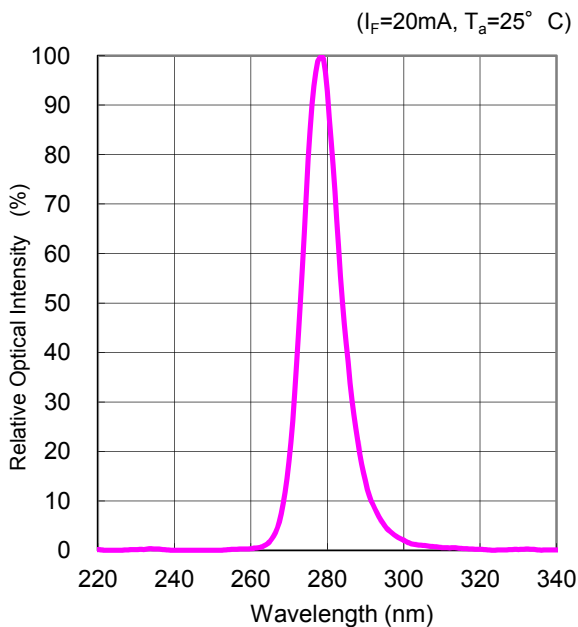

**Relative Intensity vs Peak Wavelength**

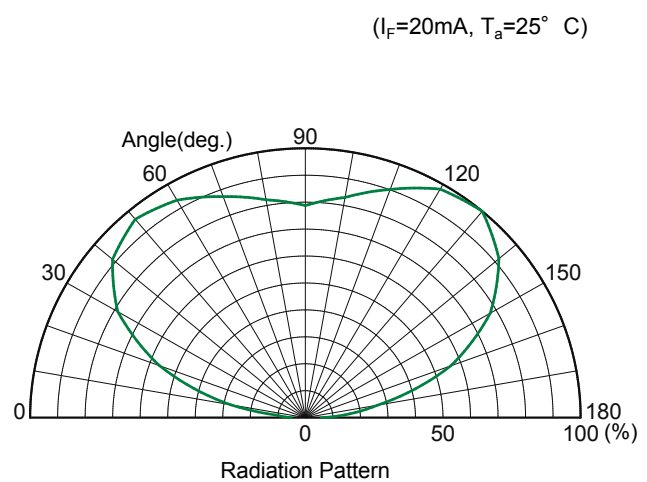

**Radiation Pattern**



	 <b>CAUTION</b>
	<ul style="list-style-type: none"> <li>• LEDs emit very strong UV radiation.</li> <li>• Don't look directly into the LED light. UV radiation can harm your eyes.</li> <li>• To prevent even inadequate exposure, wear protective eyewear.</li> <li>• If LEDs are embedded in devices, please indicate warning labels against the UV light LED used.</li> <li>• Keep out of reach of children.</li> <li>• Specification and dimension are subject to change for improvement without notice.</li> </ul>

**Radiant Flux vs Ambient Temperature**

$I_F=20\text{mA}$

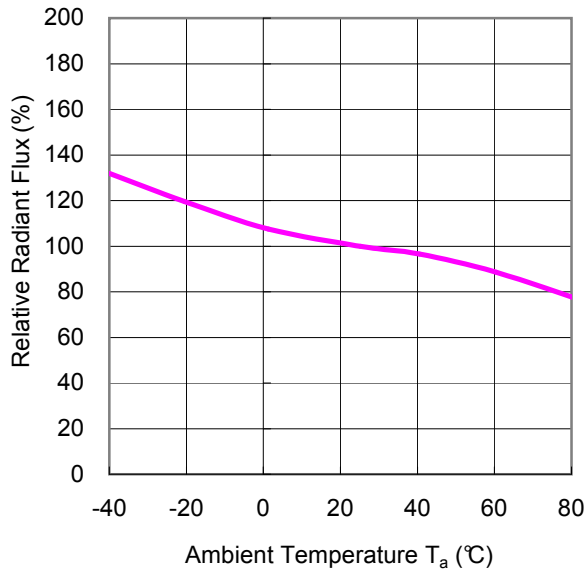

**Voltage Shift vs Ambient Temperature**

$I_F=20\text{mA}$

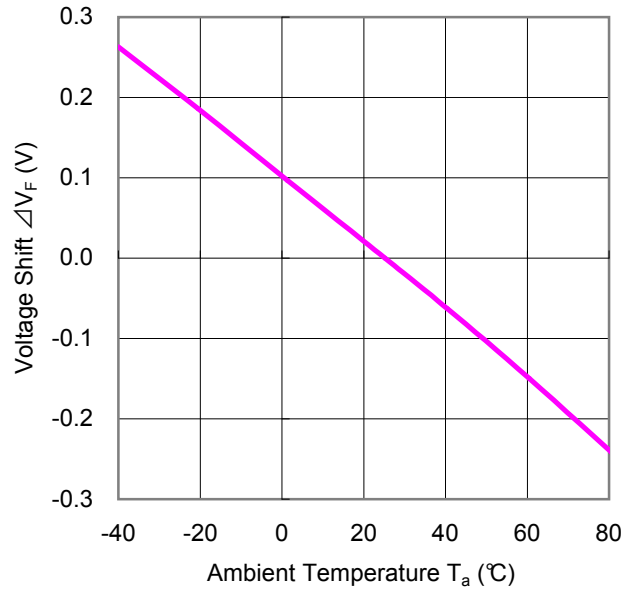

**Wavelength Shift vs Ambient Temperature**

$I_F=20\text{mA}$

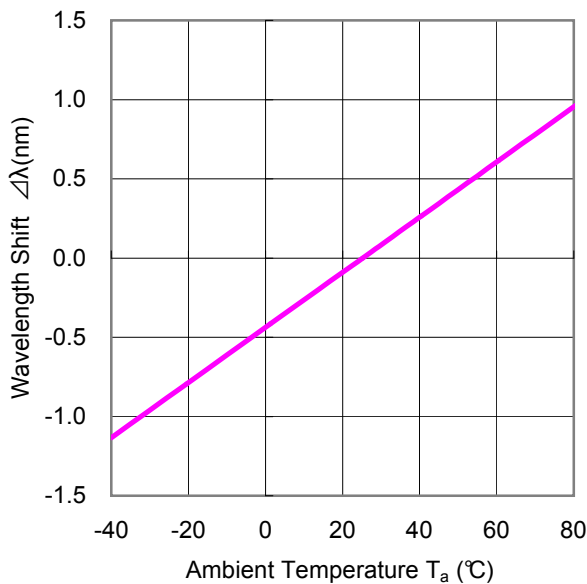

**Junction Temperature vs Forward Current**

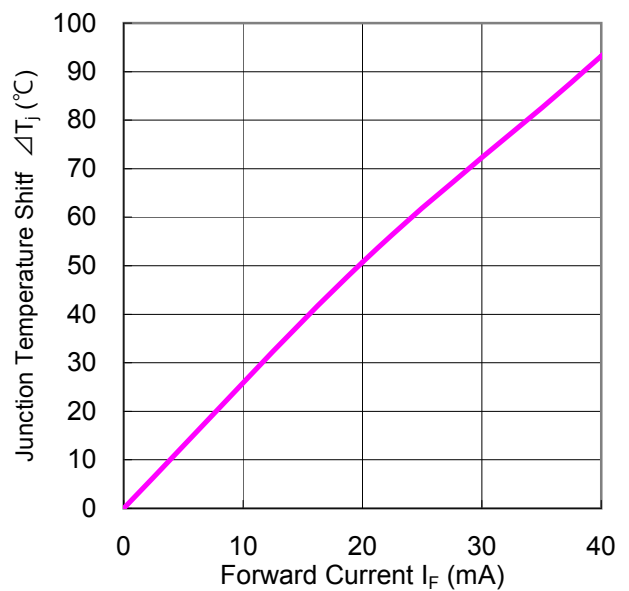

Issued September 2016

SPEC information (included design, dimension, and typical data) would be changed without prior notice.

Lead (Pb) Free Product – RoHS Compliant