

**SMC570**

High Bright Green Color SMD LED on Ceramics

SMC570 consists of an InGaAlP LED mounted on the ceramics package and is sealed with silicone or epoxy resin. It emits a spectral band of radiation at 570nm.

<Specifications>

1. Product Name: SMD Green Color LED
2. Type Number: SMC570
3. Chip:
  - Chip Material: InGaAlP/GaAs
  - Peak Wavelength: 570nm type
4. Package
  - Package: Ceramics
  - Lens: Silicone or Epoxy Resin

Outer Dimension (Unit:mm)

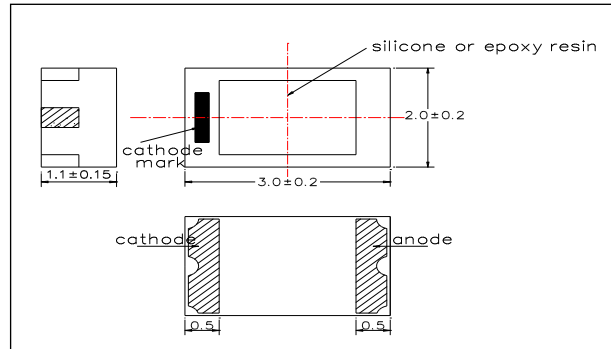

Absolute Maximum Ratings				
Item	Symbol	Maximum Rated Value	Unit	Ambient Temperature
Power Dissipation	PD	60	mW	Ta=25°C
Forward Current	IF	30	mA	Ta=25°C
Reverse Voltage	VR	5	V	Ta=25°C
Operating Temperature	TOPR	-20 ~ +80	°C	
Storage Temperature	TSTG	-30 ~ +80	°C	
Soldering Temperature*	TSOL	250	°C	

\* Soldering condition must be completed within 5 seconds at 250°C

Electro-Optical Characteristics[Ta=25°C]						
Item	Symbol	Condition	Minimum	Typical	Maximum	Unit
Forward Voltage	VF	IF=20mA		1.95	2.2	V
Reverse Current	IR	VR=5V			10	uA
Radiated Power*	PO	IF=20mA		0.2		mW
Brightness**	IV	IF=20mA		30		mcd
Radiant Intensity***	IE	IF=20mA		0.06		mW/sr
Peak Wavelength	λP	IF=20mA	560	570	580	nm
Half Width	Δλ	IF=20mA		15		nm
Viewing Half Angle	θ1/2	IF=20mA		±55		deg

\* Measured by Photodyne #500  
 \*\* Measured by Tektronix J-16  
 \*\*\* Measured by Tektronix J-6512

